

Bottom view / Вид снизу

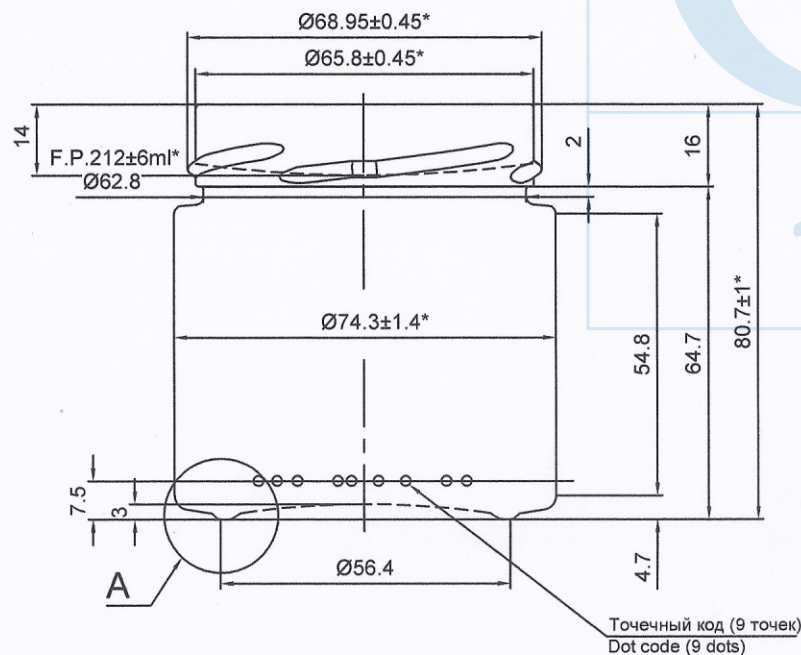
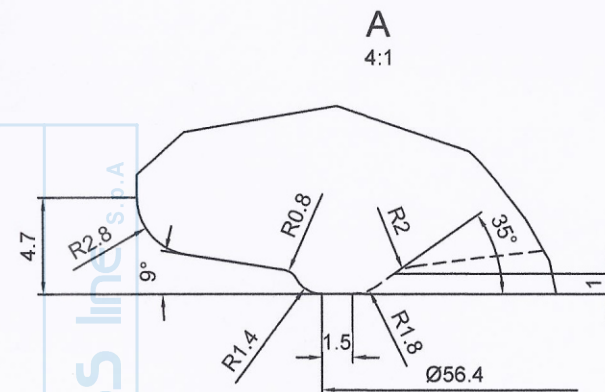
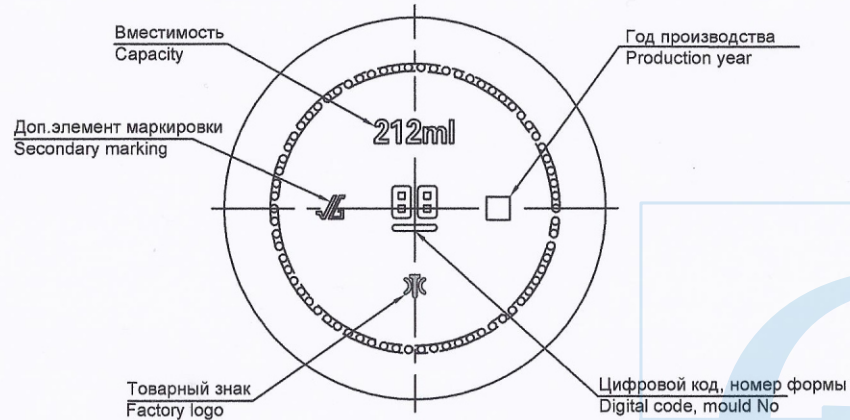

- \*Контролируемые размеры. Остальные размеры для изготовления формокомплекта. (Controlling dimensions. Other dimensions for the manufacture of mold sets.)
- Полная вместимость, см<sup>3</sup> (Full capacity, ml) - 251±6;
- Номинальная вместимость, см<sup>3</sup> (Nominal capacity, ml) - 212±6;
- Масса рекомендуемая, г (Weight recommended, g) - 175;
- Тип венчика (Finish type) -III-4-70(TO-70 DEEP);
- Толщина минимальная (Minimum Thickness):
  - стенка, мм (Wall, mm) -1,2;
  - дна, мм (Bottom, mm) -2,0.

7. Технические требования по ГОСТ 5717-91 и по ТУ У 26.1-04763746-027:2009.  
(Technical requirements according to ГОСТ 5717-91 and ТУ У 26.1-04763746-027:2009)

NAME	DATE	REVISIONS	MOLD No:			A3 CENTERGLASSLINE SPA	
V.Y.	08.12.17	Added logo on the bottom	FINISH No:				
V.Y.	02.02.18	Changed body dimens., brimf.capacity, F.P.	PROCESS	PB	MACHINE	DG 5 1/2"	JAR:
			TYPE	OW	TIP ANGLE	-	<b>ELENA 212ML</b>
			CAP. BRIMF.	251±6ml	REF MOLD:	-	CAT.No & DWG No:
			CAP. FILLPT.	212±6ml	FINISH:	III-4-70(TO-70 DEEP)	<b>3.90-III-4-70-212</b>
			FILL LINE	14mm	DRAWN	Yatsentiuk	
			WEIGHT	175g	CHECKED	Dovgopol	DATE
			COLOR	FLINT	CONFIRMED	Solomon	16/11/17
							SHEET: 1/1 SCALE: 1:1